

# 4AC16L

## PRODUCT SPECIFICATIONS

SPLIT SYSTEM AIR CONDITIONER  
UP TO 15.2 SEER2

FORM NO. 4AC16L-100 (01/2023)



### COMPRESSOR

- High-efficiency scroll compressor
- R410A refrigerant
- Internally protected against high temperature motor overload conditions
- Heavy-duty compressor sound blanket for quiet operation (optional accessory)

### CABINET

- Full metal louvered construction to protect the coil/hail protection
- Individual louver panels; 4 screws to remove for ease of coil cleaning and service
- Corner-mounted controls for easy service
- Baked polyester paint finished over galvanized steel for maximum durability
- 45-degree offset valves for easy service

### COILS

- Omniguard™ total corrosion protection technology designed coil
- Enhanced tube-and-fin coil design featuring MHT™ Technology
- Lanced fins for maximum heat transfer
- Every coil factory tested for leakproof construction
- Raised coil prevents debris from impeding airflow

### COMPONENTS

- Factory installed high pressure switch
- Thread-on pressure switches with Schrader core for simple, quick replacement
- Filter drier shipped loose for installation flexibility
- Fan orifice for smoother airflow and sound level reduction
- Charged for 15 feet of line set

### WARRANTY

10 year limited warranty on compressor  
10 year limited warranty on all parts, extended warranty available\*

*\*Warranty provides for a total of 10 years of limited warranty coverage (Standard 5-year limited parts warranty plus an additional 5-year limited extended parts warranty). Warranty must be registered online within 60 days of installation to qualify for 10-year coverage. Unregistered equipment defaults to 5-year coverage. See full warranty at [www.alliedair.com](http://www.alliedair.com) for terms, conditions and exclusions.*

### **NOTE:**

For the latest ratings, please see [www.alliedratings.com](http://www.alliedratings.com) or [www.AHRIdirectory.org](http://www.AHRIdirectory.org)



**MODEL NUMBER GUIDE**

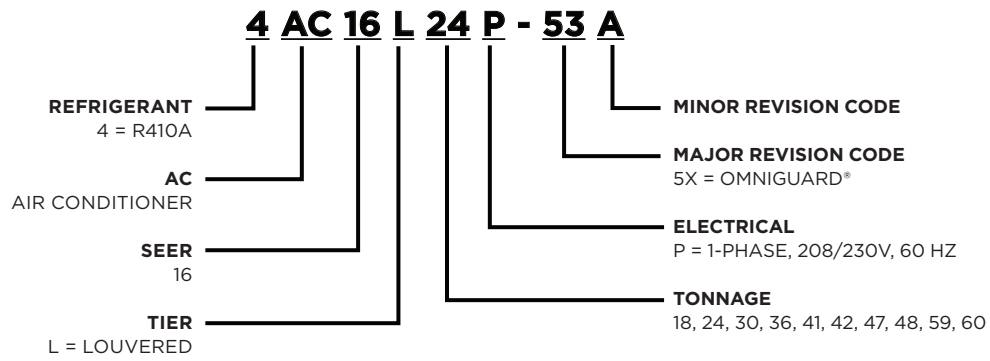

**PHYSICAL AND ELECTRICAL DATA**

Model	Voltage/Hz/Phase	Voltage Range	Min. Circuit Amp.	Max. Over Current Device (amps)	Compressor		Outdoor Fan Motor		
					Rated Load (amps)	Locked Rotor (amps)	Full Load (amps)	Rated HP	Nom. RPM
4AC16L18P-53	208-230/60/1	197-253	11.9	20	7.7	48	0.7	1/10	1075
4AC16L18P-54	208-230/60/1	197-253	11.9	20	10.0	48	0.7	1/10	1075
4AC16L24P-53	208-230/60/1	197-253	15.7	25	10.1	52	1.0	1/6	825
4AC16L24P-54	208-230/60/1	197-253	17.0	25	12.1	63	1.0	1/6	825
4AC16L30P-53	208-230/60/1	197-253	17.6	25	11.3	63	1.0	1/6	825
4AC16L36P-53	208-230/60/1	197-253	21.2	30	13.6	79	1.0	1/6	825
4AC16L41P-53	208-230/60/1	197-253	22.9	30	14.7	75	1.0	1/6	825
4AC16L42P-53	208-230/60/1	197-253	24.8	40	20.0	112	1.0	1/6	825
4AC16L42P-54	208-230/60/1	197-253	28.0	40	20.0	112	1.0	1/6	825
4AC16L47P-53	208-230/60/1	197-253	26.3	35	16.9	94	1.8	1/3	825
4AC16L48P-53	208-230/60/1	197-253	26.3	40	20.6	124	1.7	1/4	825
4AC16L48P-54	208-230/60/1	197-253	26.3	40	20.6	124	1.7	1/4	825
4AC16L59P-53	208-230/60/1	197-253	32.5	45	20.8	127	2.8	1/3	V Spd
4AC16L60P-53	208-230/60/1	197-253	34.7	50	22.2	128	1.8	1/3	825

**UNIT DIMENSIONS (IN.)**

Model	Dimensions (inch)			Shipping Weight (Lbs.)
	A - Width	B - Depth	C - Height	
4AC16L18P-53,54	24.25	24.25	29	134
4AC16L24P-53,54	28.25	28.25	29	154
4AC16L30P-53	28.25	28.25	37	169
4AC16L36P-53	28.25	28.25	29	181
4AC16L41P-53	28.25	28.25	37	192
4AC16L42P-53,54	28.25	28.25	37	211
4AC16L47P-53	32.25	32.25	33	231
4AC16L48P-53,54	28.25	28.25	37	218
4AC16L59P-53	32.25	32.25	43	253
4AC16L60P-53	32.25	32.25	43	226

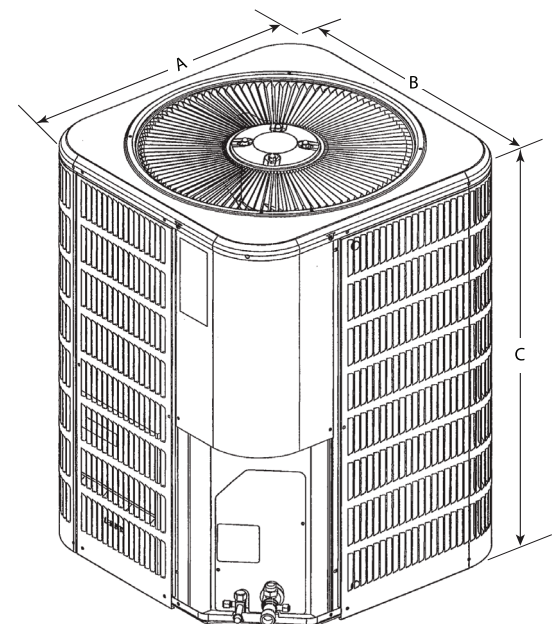

*Note:*  
Weights listed are unit weights with packaging  
Dimensions listed are unit sizes w/o packaging

**SOUND RATINGS**

Model	Sound Power <sup>1</sup>	Estimated Sound Pressure (dBA) <sup>2</sup>		
		Approximate Distance <sup>3</sup>		
		3.3 Feet (1 Meter)	6.6 Feet (2 Meters)	9.8 Feet (3 Meters)
4AC16L18P-53,54	73	65	59	55
4AC16L24P-53,54	76	68	62	58
4AC16L30P-53	76	68	62	58
4AC16L36P-53	76	68	62	58
4AC16L41P-53	74	66	60	56
4AC16L42P-53,54	76	68	62	58
4AC16L47P-53	80	72	66	62
4AC16L48P-53,54	78	70	64	60
4AC16L59P-53	77	69	63	59
4AC16L60P-53	80	72	66	62

<sup>1</sup> Rated in accordance with AHRI standard 270 (2015). AHRI Standard 270 establishes a method of rating outdoor unitary equipment in terms of Sound Power.

<sup>2</sup> Rated in accordance with AHRI standard 275 (2010). AHRI Standard 275 provides the calculations for estimating the A-Weighted Sound Pressure at a given distance from the equipment. That is a more useful number because that is what humans will hear.

<sup>3</sup> Based only on distance factor; other factors may change this value such as:

- Unit location (reflective surfaces adjacent to the unit)
- Barrier shielding sources
- Sound path/elevation
- Outside noise sources

**ACCESSORIES**

System Accessory	Where Used	Kit Number	Purpose
Liquid Line Solenoid	All models	60M52	Prevents liquid migration to the compressor especially for high liquid riser applications
Low ambient (cooling operation)	All models	34M72	Enables cooling demand down to 30 °F. Will require freeze stat, CC heater and TXV
Compressor Short Cycle Protector	All models	47J27	Delays compressor start 5-7 minutes to prevent short cycling
Hard Start	18	10J42	Scroll compressors usually do not require hard start; maybe needed for utility brown-out or low voltage areas
	24 thru 60	88M91	
Crankcase Heater	18, 24, 30, 36	93M04	Prevents liquid migration to compressor in cold weather
	41, 42	93M05	
	47, 48, 59, 60	Factory Installed	
Sound Cover	18, 24, 30, 36, 41	14W00	Lowers compressor sound level
	42, 47, 48, 59, 60	14W01	
Loss of Charge Kit	All models	84M23	Protects the compressor if refrigerant charge is too low
Additional System Accessories (indoor section)			
TXV Kit	18, 24, 30	H4TXV01	TXVs provide superior refrigerant flow control, comfort and efficiency compared to pistons
	36, 41, 42, 47, 48	H4TXV02	
	59, 60	H4TXV03	
Outdoor Thermostat - Electric Heat	All models	10Z23	Prevents electric heat operation above specific ambient conditions
Outdoor Thermostat - Mounting Box	All models	31461	Mounting box for outdoor thermostat
Freezestat	All models	93G35	Protects the compressor at low suction pressure conditions
Overflow Switch	All models	11U75	Turn the system off, if condensate water overflows due to clogged drain pipes
Blower Time Delay	All models	58M81	Improves system efficiency and comfort
Single Point Power Supply	All models	21H39	Provide single power source in one junction box
Auxiliary Blower Relay	All models	85W66	Maybe required to select multiple indoor blower speeds

**REFRIGERATION DATA**

Model	Refrig. Charge (oz.) *	Piston Size	TXV	Refrigerant Line Size		Outdoor Unit Connection		Indoor Unit Connection	
				Suction	Liquid	Suction	Liquid	Suction	Liquid
4AC16L18P-53	81	0.049	H4TXV01	3/4	3/8	3/4	3/8	3/4	3/8
4AC16L18P-54	62	0.049	H4TXV01	3/4	3/8	3/4	3/8	3/4	3/8
4AC16L24P-53	69	0.057	H4TXV01	3/4	3/8	3/4	3/8	3/4	3/8
4AC16L24P-54	81	0.057	H4TXV01	3/4	3/8	3/4	3/8	3/4	3/8
4AC16L30P-53	111	0.060	H4TXV01	3/4	3/8	3/4	3/8	3/4	3/8
4AC16L36P-53	121	0.067	H4TXV02	7/8	3/8	7/8	3/8	7/8	3/8
4AC16L41P-53	148	†	H4TXV02	7/8	3/8	7/8	3/8	7/8	3/8
4AC16L42P-53	146	0.076	H4TXV02	7/8	3/8	7/8	3/8	7/8	3/8
4AC16L42P-54	146	0.076	H4TXV02	7/8	3/8	7/8	3/8	7/8	3/8
4AC16L47P-53	180	†	H4TXV02	7/8	3/8	7/8	3/8	7/8	3/8
4AC16L48P-53	152	0.083	H4TXV02	7/8	3/8	7/8	3/8	7/8	3/8
4AC16L48P-54	160	0.083	H4TXV02	7/8	3/8	7/8	3/8	7/8	3/8
4AC16L59P-53	186	†	H4TXV03	1-1/8	3/8	7/8 **	3/8	7/8	3/8
4AC16L60P-53	203	0.097	H4TXV03	1-1/8	3/8	7/8 **	3/8	7/8	3/8

\*Factory charged for 15 feet of line set

\*\* Adapter shipped with unit

† TXV only

**COOLING PERFORMANCE WITH DTC<sup>1</sup>**

Outdoor Model	Indoor Model	Capacity (BTUH)	EER2	SEER2
4AC16L18P-53,54	EAC4X24B	18,000	11.5	13.4
4AC16L24P-53,54	EAC4X24B	23,600	11.7	13.4
4AC16L30P-53	EAC4X30B	28,200	11.5	13.4
4AC16L36P-53	EAC4X36B	34,000	11.2	13.4
4AC16L41P-53	EAC4X49C	36,600	11.7	13.4
4AC16L42P-53,54	EAC4X49C	39,500	11.2	13.4
4AC16L47P-53	EAC4X60C	46,500	12.2	13.4
4AC16L48P-53,54	EAC4X60C	45,500	11.5	13.4
4AC16L59P-53	EAC4X60C	56,000	11.7	13.4
4AC16L60P-53	EAC4X60C	58,000	11.5	13.4

<sup>1</sup> DTC = Designated Tested Combination**NOTE:**

For the latest AHRI system matches please visit [www.alliedratings.com](http://www.alliedratings.com) or [www.AHRIdirectory.org](http://www.AHRIdirectory.org)



1-800-448-5872

All specifications and illustrations subject to change without notice and without incurring obligations.